

A climate of innovation™

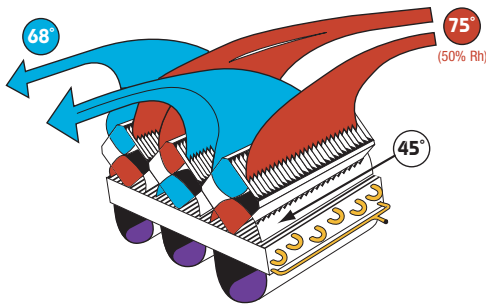

Indoor Air Dehumidifiers



DHOP Series, 3,000-CFM Indoor Air Dehumidifier, Clean Room, Portland, OR—Features Super-Efficient MSP™ Technology
US Patent 5,816,315, foreign patents pending

A Fresh Approach To Improving Indoor Air Quality

Now you can realize all the comfort and cost benefits of low humidity air. Nautica's super-efficient, Multiple Small Plate (MSP™) technology provides energy-saving dehumidification, which allows the building's temperature setting to be raised in the summer, without sacrificing a comfortable environment.

Nautica dehumidifiers are available in complete packaged systems or split systems—with options to integrate with virtually any HVAC system, for any size building. Plus our units require less space and less maintenance than conventional dehumidifiers.

● **Reduce Energy Costs Up To 50%**

● **Precisely Control Humidity**

● **Prevent Mold and Mildew**

● **Split or Packaged Units**

CORPORATE OFFICE:

200-19 East Second Street
Huntington Station, NY 11746
Phone: 631.424.8030
Fax: 631.351.8249
info@nauticadehumid.com

www.nauticadehumid.com

SALES:

Toll free phone: 866.628.8424
Toll free fax: 866.628.8425
sales@nauticadehumid.com

ENGINEERING:

Toll free phone: 877.662.8842
Fax: 631.351.8249
engineering@nauticadehumid.com

Key Benefits & Features

- Take control of problematic indoor humidity in occupied or unoccupied spaces
- Patented, super-efficient MSP™ technology requires less space, less energy, less maintenance
- Delivers dehumidified air with a latent heat ratio of over 60%
- Lowers operating expenses—reduces load on cooling equipment
- Complete integrated packaged system simplifies installation and maintenance
- Dehumidification with heating options lets you specify the best overall configuration
- Indoor or outdoor installation options available
- Capacities from 5 to 175 lb/hr and up
- Horizontal and vertical unit configurations

Indoor Air Dehumidifiers—Application Options

DH Integral (Indoor/Outdoor)

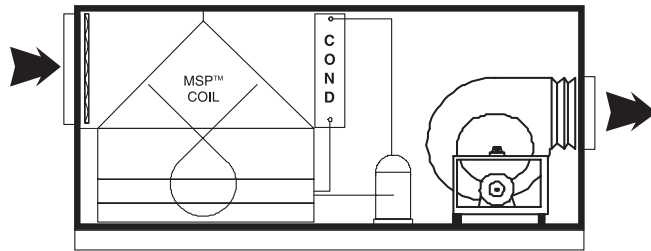

DH Packaged (Outdoor)

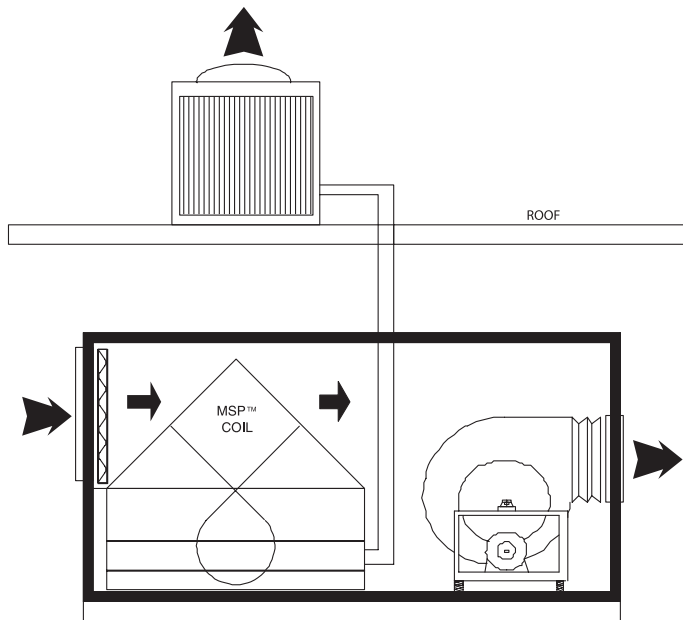
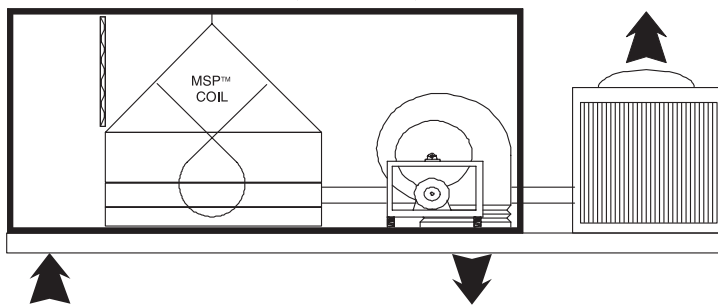

DH Split (Indoor)

Additional Features

- Split or packaged units
- Indoor & outdoor construction
- Air cooled, water cooled or chilled water
- Heat pumps—water and air source
- Double-wall construction
- Stainless steel drain pans
- Internally isolated fans
- Modular designs
- Cooling option

More Options

- Hot water or steam heating coils
- Indirect gas heating
- Electric heat
- Cooling
- Single point electrical connections
- Unit mounted disconnect switch
- Self-contained control system
- High efficiency MSP™ heat exchangers
- Variable frequency drives
- Roof curbs— isolation and standard

A climate of innovation™

NAUTICA
DEHUMIDIFIERS

CORPORATE OFFICE: 200-19 East Second Street, Huntington Station, NY 11746 • Phone: 631.424.8030 • Fax: 631.351.8249 • info@nauticadehumid.com

SALES: Toll free phone: 866.628.8424 • Toll free fax: 866.628.8425 • sales@nauticadehumid.com

ENGINEERING: Toll free phone: 877.662.8842 • Fax: 631.351.8249 • engineering@nauticadehumid.com

www.nauticadehumid.com